

JAAN BENCH. UPHOLSTERED BENCH

DESIGN: EOOS.

Construction	wooden frame	Equipment	Optionally, the frame can be equipped with rear and side storage shelves.
Frame	aluminium		
Upholstery	<p>seat: fixed upholstery with micro pocket spring core</p> <p>back: fixed upholstery</p> <p>seat and back cushion: cold foam with polyester fiber wrap</p>		

module	<input type="checkbox"/> left <input type="checkbox"/> right
base frame	<input type="checkbox"/> powder-coated matt bronze <input type="checkbox"/> powder-coated matt black
glides	<input type="checkbox"/> felt glides <input type="checkbox"/> synthetic glides <input type="checkbox"/> stoppers
board	<input checked="" type="checkbox"/> .109 Fenix black

Ordering advice

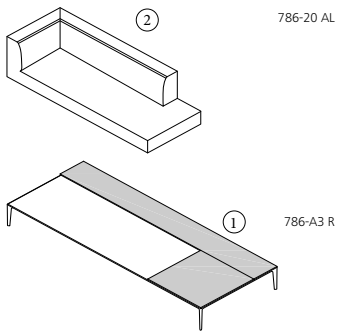

1. First select base with or without board.

2. Then select a matching upholstered module.

3. In case more than one module is being ordered, please add a drawing of the layout.

Sample configurations: Combination of several Jaan Bench models

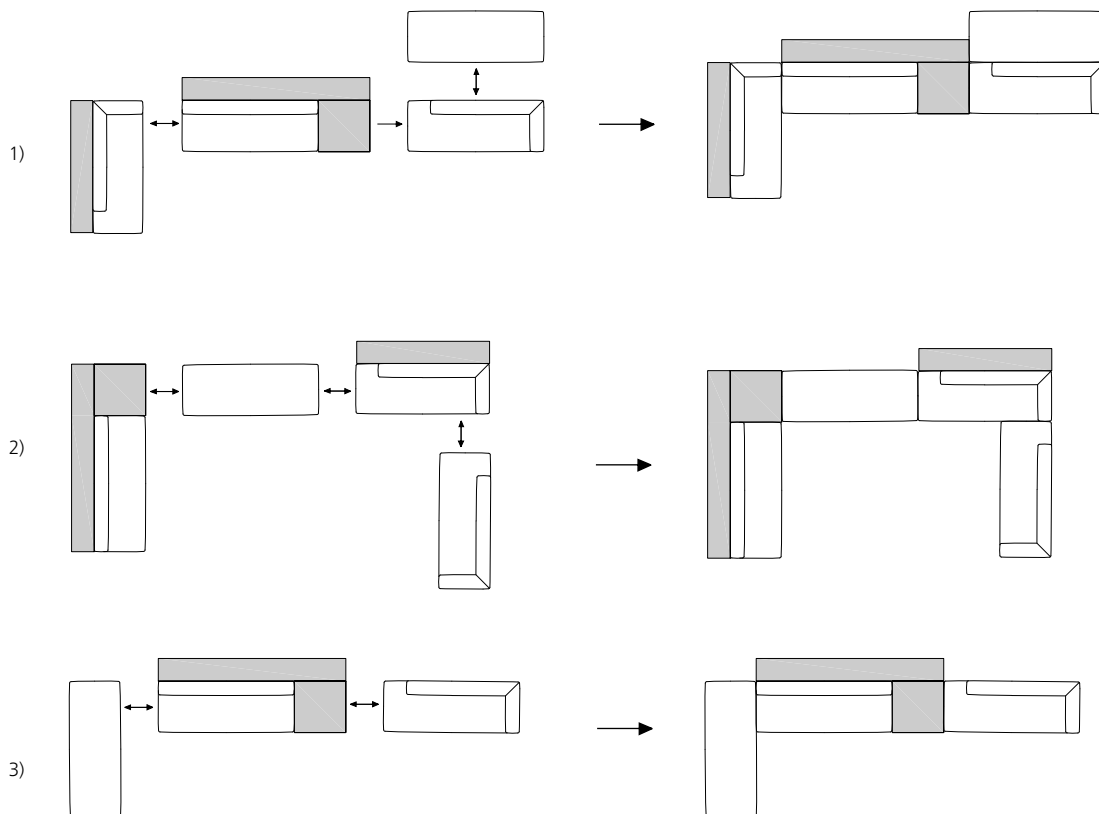
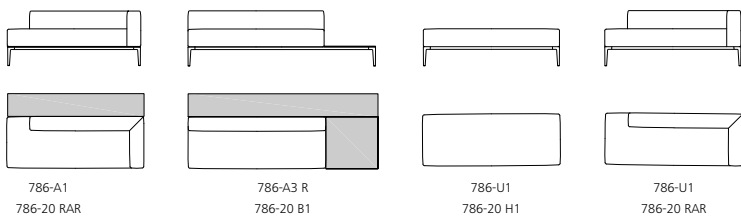

bench frame

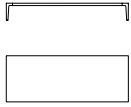

786-U1
W 180 D 68 H 25

W 70¾ D 26¾ H 9¾



786-A1
W 180 D 99 H 26

W 70¾ D 39 H 10¼



786-A2 L

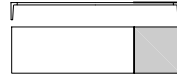

786-A2 R

786-A2
W 249 D 68 H 26

W 98 D 26¾ H 10¼

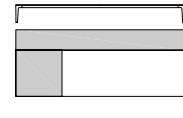

786-A3 L

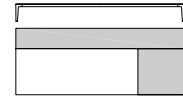

786-A3 R

786-A3
W 249 D 99 H 26

W 98 D 39 H 10¼

bench corpus

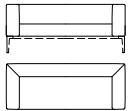

786-20
W 182 D 70 H 74
SH 44 SD 50

W 71¾ D 27½ H 29¼
SH 17¼ SD 19¾

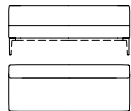

786-20 B1
W 182 D 70 H 74
SH 44 SD 50

W 71¾ D 27½ H 29¼
SH 17¼ SD 19¾

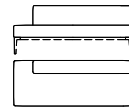

786-20 B2 L

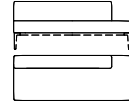

786-20 B2 R

786-20 B2
W 182 D 70 H 74
SH 44 SD 50

W 71¾ D 27½ H 29¼
SH 17¼ SD 19¾

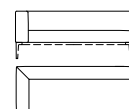

786-20 AL

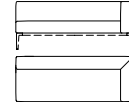

786-20 AR

786-20 A
W 182 D 70 H 74
SH 44 SD 50

W 71¾ D 27½ H 29¼
SH 17¼ SD 19¾

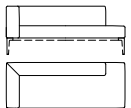

786-20 RAL

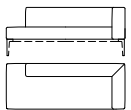

786-20 RAR

786-20 RA
W 182 D 70 H 74
SH 44 SD 50

W 71¾ D 27½ H 29¼
SH 17¼ SD 19¾

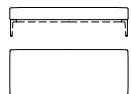

786-20 H1
W 182 D 70 H 44
SH 44 SD 70

W 71¾ D 27½ H 17¼
SH 17¼ SD 27½

configuration example



786-Version A21
W 251 D 101

W $98\frac{3}{4}$ D $39\frac{3}{4}$

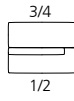

786-Version B21
W 182 D 140

W $71\frac{3}{4}$ D 55

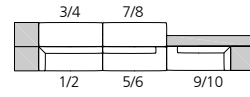

786-Version C21
W 684 D 140

W $269\frac{1}{4}$ D 55